



---

**KRAMER ELECTRONICS, Ltd.**

# **USER MANUAL**

**Distribution Amplifiers Models:**

**VM-1010, VM-1015, VM-1021,  
VM-1042, VM-1044, VM-1055, VM-54**

**IMPORTANT: Before proceeding, please read paragraph entitled  
"Unpacking and Contents"**



## Table of Contents

Section	Name	Page
1	INTRODUCTION	1
1.1	A Word On Distribution Amplifiers	1
1.2	Factors Affecting Quality of Results	2
2	SPECIFICATIONS	3
3	HOW DO I GET STARTED?	4
4	UNPACKING AND CONTENTS	4
4.1	Optional Accessories	4
5	VM SERIES AMPLIFIERS	5
5.1	Getting To Know Your VM-1010 Amplifier	5
5.2	Getting To Know Your VM-1015 Amplifier	6
5.3	Getting To Know Your VM-1021 Amplifier	7
5.4	Getting To Know Your VM-1042 Amplifier	9
5.5	Getting To Know Your VM-1044 Amplifier	10
5.6	Getting To Know Your VM-1055 Amplifier	11
5.7	Getting To Know Your VM-54 Amplifier	12
6	INSTALLATION	14
6.1	Rack Mounting	14
7	CONNECTING TO VIDEO DEVICES	15
8	USING THE VIDEO AMPLIFIERS	15
8.1	Powering On The Amplifier	15
8.2	Looping	15
8.3	Level Control	16
8.4	Equalization Control	16
8.5	Coupling	17
8.6	Black Level Clamping	17
8.7	Sync Tip Clamping	17
9	TAKING CARE OF YOUR VIDEO AMPLIFIER	17
10	TROUBLESHOOTING	18
10.1	Power And Indicators	18
10.2	Video Signal	18
	Limited Warranty	20

## List Of Illustrations

Figure		Page
1	VM-1010 Front/Rear Panel Features	5
2	VM-1015 Front/Rear Panel Features	6
3	VM-1021 Front/Rear Panel Features	7
4	VM-1042 Front Panel Features	9
5	VM-1044 Front/Rear Panel Features	10
6	VM-1055 Front/Rear Panel Features	11
7	VM-54 Front/Rear Panel Features	12

## List Of Tables

Table		Page
1	VM-1010 Front Panel Features	5
2	VM-1010 Rear Panel Features	6
3	VM-1015 Front Panel Features	7
4	VM-1015 Rear Panel Features	7
5	VM-1021 Front Panel Features	8
6	VM-1021 Rear Panel Features	8
7	VM-1042 Front/Rear Panel Features	9
8	VM-1044 Front/Rear Panel Features	11
9	VM-1055 Front/Rear Panel Features	12
10	VM-54 Front Panel Features	13
11	VM-54 Rear Panel Features	14
12	Signals Supported By Model	15



## 1. INTRODUCTION

Congratulations on your purchase of this Kramer Electronics amplifier. Since 1981 Kramer has been dedicated to the development and manufacture of high quality video/audio equipment. The Kramer industrial line has become an integral part of many of the best production and presentation facilities around the world. In recent years, Kramer has redesigned and upgraded most of the industrial line, making the best even better. Kramer's line of professional video/audio electronics is one of the most versatile and complete available, and is a true leader in terms of quality, workmanship, price/performance ratio and innovation. In addition to the Kramer line of high quality amplifiers, such as the one you have just purchased, Kramer also offers a full line of high quality industrial and broadcast switchers, processors, interfaces, controllers and computer-related products. Kramer welcomes your inquiries for Kramer equipment or custom-manufactured products, engineering, private labeling and OEM manufacturing per your specifications.

This manual includes configuration, operation and information for the following products from the Kramer VM line of distribution amplifiers. All these VM amplifiers are similar in operation and features.

- **VM-1010** - 1:10 Video Distributor
- **VM-1015** - 1:5 Video Distributor
- **VM-1021** - 1:20 Video Distributor
- **VM-1042** - 4:2 Video Component Distributor
- **VM-1044** - 4:4 Video Distributor
- **VM-1055** - 1:5 Five Channel Video Component Distributor
- **VM-54** - Looping Video Distributor

### 1.1 A Word On Distribution Amplifiers

Distribution amplifiers are used to distribute one source to several acceptors for simultaneous recording or monitoring of one source, with no discernible signal degradation. They vary in the number of inputs, looping capability, programming capability, number of outputs, operating format, bandwidth and input/output coupling. A good quality distribution amplifier amplifies the incoming signal, pre-compensates the signal for potential losses (resulting from the use of long cables, noisy source, etc.) and generates several identical buffered and amplified outputs. Often, a signal processor is inserted between the source and the distribution amplifier for correction and fine-tuning of the source signal before multiplication, so that all copies are corrected in the same way. The front panels of these Kramer amplifiers are designed to be simple to operate.



---

## 1.2 Factors Affecting Quality of Results

There are many factors affecting the quality of results when signals are transmitted from a source to an acceptor:

Connection cables - Low quality cables are susceptible to interference, they degrade signal quality due to poor matching and cause elevated noise levels. They should therefore be of the best quality.

Sockets and connectors of the sources and acceptors - So often ignored, they should be of highest quality, since "Zero  $\Omega$ " connection resistance is the target. Sockets and connectors also must match the required impedance ( $75\Omega$  in video). Cheap, low quality connectors tend to rust, thus causing flaws in the signal path.

Amplifying circuitry - Must have quality performance when the desired end result is high linearity, low distortion and low noise operation.

Distance between sources and acceptors - Plays a major role in the final result. For long distances (over 15 meters) between sources and acceptors, special measures should be taken in order to avoid cable losses. These include using higher quality cables or adding line amplifiers.

Interference from neighboring electrical appliances - These can have an adverse effect on signal quality. Balanced audio lines are less prone to interference, but unbalanced audio should be installed far from any mains power cables, electric motors, transmitters, etc. even when the cables are shielded.



## 2. SPECIFICATIONS

	VM-1010	VM-1015	VM-1021	VM-1042	VM-1044	VM-1055	VM-54
<b>Configuration</b>	2X CV	1X CV	1X CV	4XCV/RGB	4XCV/RGB	5XCV/ RGB HSVS	1X CV, 3comp
<b>Input Type</b>	CV	CV	CV	CV/RGB	CV/RGB	CV/RGB HSVS	CV/Comp
<b>Input Connections</b>	BNC	BNC	BNC	BNC	BNC	BNC	BNC
<b>Input Level</b>	1Vpp/75Ω looping	1Vpp/75Ω looping	1Vpp/75Ω looping	1Vpp/75Ω looping	1Vpp/75Ω	1Vpp/75Ω	1Vpp/75Ω looping
<b>Output Type</b>	1X10 or 2X5	5XCV	CV 3Vpp Max.	2X4 CV/RGB 2Vpp	4X4 CV/RGB	5X5CV/ RGB HSVS	3x18 Composite/ CV
<b>Output Connector</b>	BNC	BNC	BNC	BNC	BNC	BNC	BNC
<b>Output Level</b>	1Vpp/75Ω	1Vpp/75Ω	1Vpp/75Ω	1Vpp/75Ω	1Vpp/75Ω	1Vpp/75Ω	1Vpp/75Ω
<b>Output Coupling</b>	DC/AC	AC/ DC/ Clamped	AC/ DC/ Clamped	DC	DC	DC	DC/AC
<b>S/N Ratio</b>	74dB	75dB	74dB	73dB	74dB	74dB	70dB
<b>Bandwidth</b>	220MHz -3dB	340MHz -3dB	350 MHz -3dB	200 MHz -3dB	320 MHz -3dB	300 MHz -3dB	350MHz
<b>Differential Gain</b>	0.05%.	0.08%.	0.1%.	0.05%.	0.05%.	0.1%.	0.03%
<b>Differential Phase</b>	0.05Deg	0.12Deg	0.07Deg	0.05Deg	0.05Deg	0.1Deg	0.09Deg
<b>K-Factor</b>	<0.05%.	<0.03%.	<0.03%.	<0.05%.	0.1%.	0.05%.	<0.05%
<b>Non Linearity</b>	0.2%	<0.1%.	0.1%.	<0.1%.	<0.1%.	0.1%.	0.2%
<b>EQ. Control</b>	0 to 2.5dB @ 100% color bar, 4.43MHz	0 to 2.7dB @ 100% color bar, 4.43MHz	0 to 2.9dB @ 100% color bar, 4.43MHz	0 to 1.3dB @ 100% color bar, 4.43MHz	0 to 0.9dB @ 100% color bar, 4.43MHz	No equalization	0 to 2.3dB
<b>DC Clamp</b>	Not clamped	0 V DC Black Level, or sync bottom TIP	0 V DC Black Level, or sync bottom TIP	Not clamped	Not clamped	Not clamped	Not clamped
<b>Level Control</b>	-1.4dB to +2.5dB	-1.2dB to +2.8dB (trimmer)	4 accessible trimmers	-2.2dB to +2.0dB	-1.1dB to +2.5dB	Fixed gain=1	24 accessible trimmers
<b>Dimensions</b>	19" (W), 7" (D), 1U (H) 48.26 cm x 17.78 x 4.5cm	19" (W), 7" (D), 1U (H) 48.26 cm x 17.78 x 4.5cm	19" (W), 7" (D), 1U (H) 48.26 cm x 17.78 x 4.5cm	19" (W), 7" (D), 1U (H) 48.26 cm x 17.78 x 4.5cm	19" (W), 7" (D), 1U (H) 48.26 cm x 17.78 x 4.5cm	19" (W), 7" (D), 1U (H) 48.26 cm x 17.78 x 4.5cm	19" (W), 7" (D), 2U (H) 48.26 cm x 17.78 x 9 cm
<b>Weight</b>	2.5kg (5.55lb) Approx.	2.42kg (5.38lb) approx.	2.66kg (5.91lb) approx.	2.5kg (5.55lb) approx.	2.54kg (5.64lb) approx.	2.66kg (5.91lb) approx.	3.98kg (8.84lb) approx.
<b>Power consumption</b>	10.3VA	4.6VA	6.7VA	3.2VA	4.6VA	5.3VA	21.39VA
<b>Power Source</b>	230V/115V AC 50/60Hz	230V/115V AC 50/60Hz	230V/115V AC 50/60Hz	230V/115V AC 50/60Hz	230V/115V AC 50/60Hz	230V/115V AC 50/60Hz	230V/115V AC 50/60Hz



### 3. HOW DO I GET STARTED?

The fastest way to get started is to take your time and do everything right the first time. Taking 15 minutes to read the manual may save you a few hours later. You don't even have to read the whole manual. At the beginning of each section, you'll find an overview of the section. So if the section doesn't apply to you, you don't have to spend your time reading it.

### 4. UNPACKING AND CONTENTS

The items contained in your Kramer VM Amplifier packaging are listed below. Please save the original box and packaging materials for possible future transportation and shipment of the Amplifier.

- Amplifier (rack-mountable)
- AC power cable
- User Manual
- 4 rubber feet

For additional information regarding optional cables and optional accessories contact your Kramer dealer.

#### 4.1 Optional Accessories

The following Kramer accessories can enhance implementation of your amplifier.

- **SP-11** - (Video/Audio Processor) can be serially connected between the video/audio source and the VM amplifier for video and audio control/correction. The machine provides camera control and luminance/white balance correction. The SP-11 is also capable of performing Composite to Y/C conversion and bi-directional transcoding. The machine allows full control over the video signal: Video gain down to full fade, log or linear Definition control, log or linear Contrast control, Color saturation control, Black Level control, Red, Green and Blue controls and a Screen Splitter control for "before-after" comparison. The Input switch control is "Audio-follow-Video".
- **SP-3001** - (Component Video Processor) can be serially connected to the VM amplifier in order to achieve full control of component video. The SP -3001 has 3 looping Component Video inputs and 9 outputs- three for each component; thus it serves as a Component DA as well. The SP -3001 allows full control of Gain, Contrast, Definition and black level of the Y channel and individual Gain and Black level controls of the R-Y and B-Y channels. A Screen Splitter control for "before-after" comparison is also built in.
- **611T/611R** - (611T full bandwidth Fiber Optic Transmitter and 611R matching Fiber Optic Receiver) Part of the KRAMER TOOLS series, and designed for studio and other demanding applications. These machines, in combination, may be used to send one of the distributed channels to distances of 5-25Km. The 611T and 611R use state-of-the-art fiber optic circuitry and allow the user (via rear panel trimmers) to adjust input and output video levels and high frequency peaking to achieve best performance. Both machines, like all KRAMER TOOLS, are fed from a 12V DC source, making them perfectly suitable for fieldwork as well.



- **VIDEO TESTER** - A new, unique, patented, indispensable tool for the video professional, the Video Tester is used to test a video path leading to/from an amplifier. By pressing only one touch switch it can trace missing signals, distinguish between good and jittery (VCR sourced) signals, and identify the presence of good signals. Whenever a video signal is missing, because of bad connections, cable breaks or faulty sources, the Video Tester is all you need.

## 5. VM SERIES AMPLIFIERS

This section describes all the controls and connections of your amplifier. Understanding all of the controls and connections helps you realize its full power.

### 5.1 Getting To Know Your VM-1010 Amplifier

The KRAMER VM-1010 is full broadcast, state-of-the-art, Programmable Video Distribution Amplifier designed for studio and other demanding applications. The VM-1010 has two looping video inputs, each splitting to 5 outputs. The user may select 2x1:5 or 1:10 operation via front panel control switches. Several VM-1010 units may be chained through the looping inputs. Output signals are (user selectable) DC or AC coupled for maximum flexibility.

Front/rear panel features of the VM-1010 are described in Figure 1, Table 1 and Table 2.

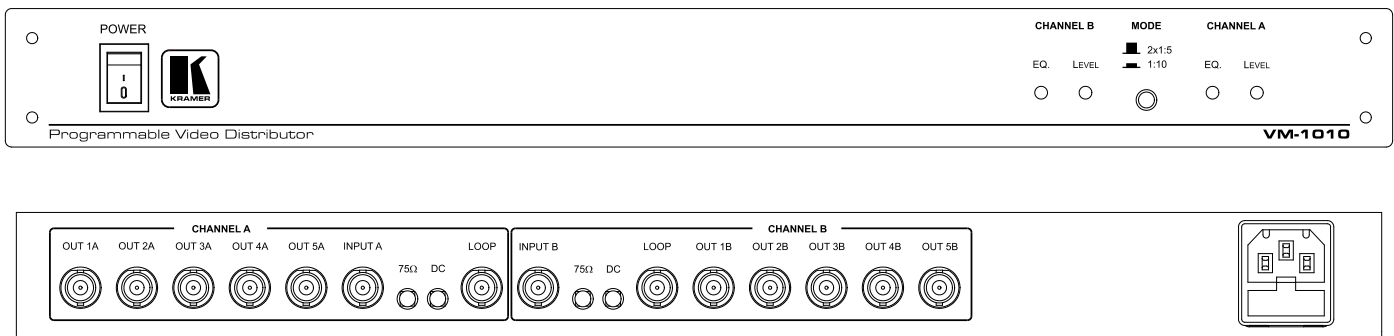

**Figure 1: VM-1010 Front/Rear Panel Features**

**Table 1: VM-1010 Front Panel Features**

No.	Feature	Function
1.	Power switch	Illuminated switch: Supplies power to the unit.
2.	<b>EQ trimmer (CHANNEL B)</b>	Controls cable equalization of channel B outputs.
3.	<b>Level trimmer (CHANNEL B)</b>	Controls video level of channel B outputs.
4.	<b>MODE (2 x 1:5, 1:10)</b> pushbutton	Selects either 1:10 or 2 x 1:5 operation.
5.	<b>EQ trimmer (CHANNEL A)</b>	Controls cable equalization of channel A outputs.
6.	<b>Level trimmer (CHANNEL A)</b>	Controls video level of channel A outputs.



**Table 2: VM-1010 Rear Panel Features**

No.	Feature	Function
1.	<b>OUT 1A -5A</b> BNC connectors	5 amplified and buffered video outputs.
2.	<b>INPUT A</b> BNC connector	Video input.
3.	<b>75Ω</b> pushbutton	Selects " <b>75Ω</b> " or " <b>HI-z</b> " impedance (for looping select " <b>Hi-z</b> ").
4.	<b>DC</b> pushbutton	Selects DC coupling when pushed.
5.	<b>LOOP</b> BNC connector	Provides video looping capability to increase number of outputs.
6.	<b>INPUT B</b> BNC connector	Video input.
7.	<b>75Ω</b> pushbutton	Selects " <b>75Ω</b> " or " <b>HI-z</b> " impedance (for looping select Hi-z).
8.	<b>DC</b> pushbutton	Selects DC coupling when pushed.
9.	<b>LOOP</b> BNC connector	Provides video looping capability to increase number of outputs.
10.	<b>OUT 1B -5B</b> BNC connectors	5 amplified and buffered video outputs.
11.	Power Connector	A 3-prong AC connector allows power to be supplied to the unit. Directly underneath this connector, a fuse holder houses the appropriate fuse.

## 5.2 Getting To Know Your VM-1015 Amplifier

The KRAMER VM-1015 is a full broadcast, state-of-the-art 1:5 Video Distribution Amplifier designed for studio and other demanding applications. The VM-1015 splits a single input source into five identical outputs with no discernible signal degradation. Output signals can either be AC or DC coupled, black level or sync tip (signal bottom) clamped, thus allowing the machine to function in all video environments. The machine may be used to distribute analog or SDI (Serial Digital) video signals, composite or single component. Video bandwidth of well over 340MHz and superb specifications make the VM-1015 the ultimate distributor for all video applications.

Front/rear panel features of the VM-1015 are described in Figure 2, Table 3 and Table 4.

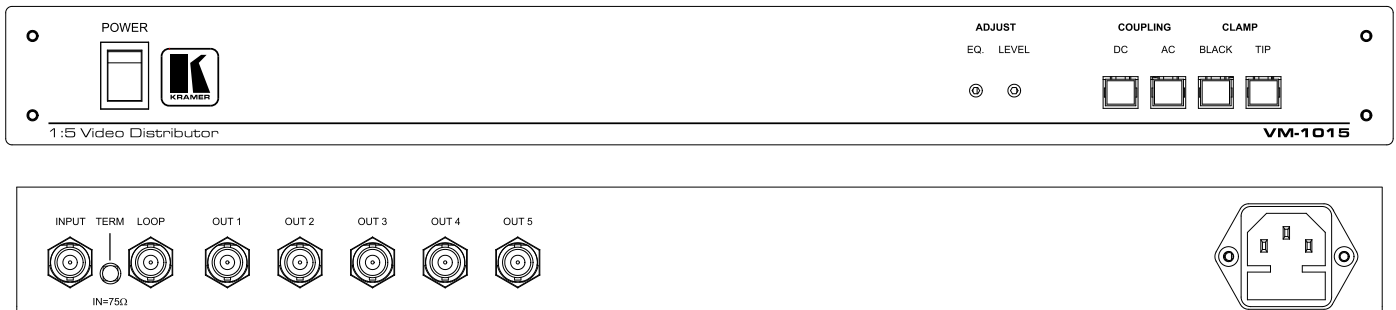

**Figure 2: VM-1015 Front/Rear Panel Features**





**Table 3: VM-1015 Front Panel Features**

No.	Feature	Function
1.	Power Switch	Illuminated switch: Supplies power to the unit.
2.	<b>EQ</b> trimmer ( <b>ADJUST</b> )	Controls cable equalization of the video outputs.
3.	<b>LEVEL</b> trimmer ( <b>ADJUST</b> )	Controls video level of the video outputs.
4.	<b>DC (COUPLING)</b> switch	Selects DC coupling when pushed.
5.	<b>AC (COUPLING)</b> switch	Selects AC coupling when pushed.
6.	<b>BLACK (CLAMP)</b> switch	Clamps video signal to the black level when pressed (best used for Composite or Component video).
7.	<b>TIP (CLAMP)</b> switch	Clamps video signal to the sync tip (signal bottom) level when pressed (best used for RGB signals).

**Table 4: VM-1015 Rear Panel Features**

No.	Feature	Function
1.	<b>INPUT</b> BNC connector	Video input
2.	<b>TERM</b> pushbutton	Selects “ <b>75Ω</b> ” or “ <b>HI-z</b> ” impedance when pressed (for looping select “ <b>Hi-z</b> ”).
3.	<b>LOOP</b> BNC connector	Provides video looping capability to increase number of outputs.
4.	<b>OUT 1-5</b> BNC connectors	5 amplified, buffered and clamped video outputs.
5.	Power Connector	A 3-prong AC connector allows power to be supplied to the unit. Directly underneath this connector, a fuse holder houses the appropriate fuse.

### **5.3 Getting To Know Your VM-1021 Amplifier**

The KRAMER VM-1021 is a full broadcast, state-of-the-art, 1:20 Video Distribution Amplifier designed for studio and other demanding applications. The VM-1021 splits a single input source into twenty identical outputs with no discernible signal degradation. Output signals can either be AC or DC coupled, black level or sync tip clamped, thus allowing the machine to function in all video environments. The outputs are divided into 4 sets of five each, where each set may be individually trimmed (level and EQ) for maximal flexibility. The machine may be used to distribute analog or SDI (Serial Digital) video signals, composite or single component. Video bandwidth of well over 350MHz and superb specifications make the VM-1021 the ultimate distributor for all video applications. Front/rear panel features of the VM-1021 are described in Figure 3, Table 5 and Table 6.

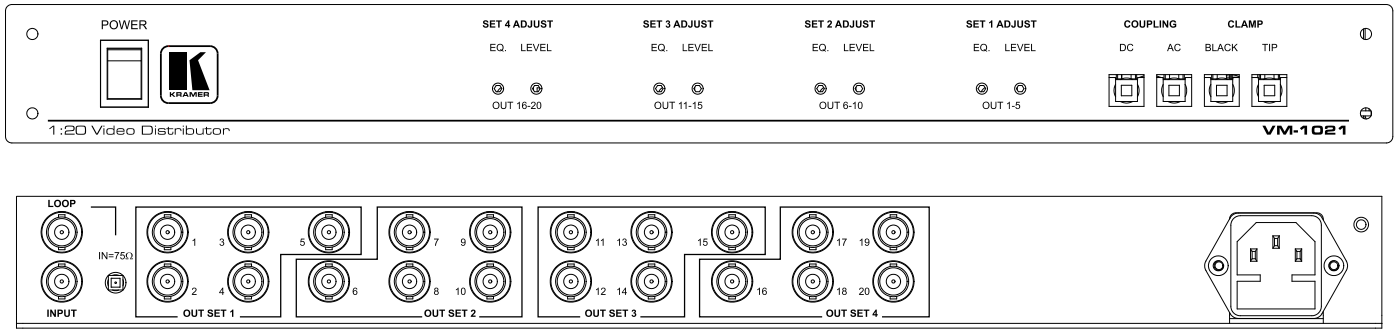

**Figure 3: VM-1021 Front/Rear Panel Features**

**Table 5: VM-1021 Front Panel Features**

No.	Feature	Function
1.	Power Switch	Illuminated switch: Supplies power to the unit.
2.	<b>EQ</b> trimmer ( <b>SET 4 ADJUST</b> )	Controls cable equalization of SET 4 video outputs.
3.	<b>LEVEL</b> trimmer ( <b>SET 4 ADJUST</b> )	Controls level of SET 4 video outputs.
4.	<b>EQ</b> trimmer ( <b>SET 3 ADJUST</b> )	Controls cable equalization of SET 3 video outputs.
5.	<b>LEVEL</b> trimmer ( <b>SET 3 ADJUST</b> )	Controls level of SET 3 video outputs.
6.	<b>EQ</b> trimmer ( <b>SET 2 ADJUST</b> )	Controls cable equalization of the SET 2 video outputs.
7.	<b>LEVEL</b> trimmer ( <b>SET 2 ADJUST</b> )	Controls level of SET 2 video outputs.
8.	<b>EQ</b> trimmer ( <b>SET 1 ADJUST</b> )	Controls cable equalization of the SET 1 video outputs.
9.	<b>LEVEL</b> trimmer ( <b>SET 1 ADJUST</b> )	Controls level of the SET 1 video outputs.
10.	<b>DC (COUPLING)</b> switch	Selects DC coupling when pushed.
11.	<b>AC (COUPLING)</b> switch	Selects AC coupling when pushed.
12.	<b>BLACK (CLAMP)</b> switch	Clamps video signal to the black level when pressed (best used for Composite or Component video).
13.	<b>TIP (CLAMP)</b> switch	Clamps video signal to the sync tip level when pressed (best used for RGB signals).

**Table 6: VM-1021 Rear Panel Features**

No.	Feature	Function
1.	<b>INPUT</b> BNC connector	Video input
2.	<b>TERM</b> pushbutton	Selects “75Ω“ or “HI-Z” impedance when pressed (for looping select "Hi-z").
3.	<b>LOOP</b> BNC connector	Provides video looping capability to increase number of outputs.
4.	<b>OUT 1-5</b> BNC connectors ( <b>SET 1</b> )	SET 1 of 5 amplified buffered and clamped video outputs.
5.	<b>OUT 1-5</b> BNC connectors ( <b>SET 2</b> )	SET 2 of 5 amplified buffered and clamped video outputs.
6.	<b>OUT 1-5</b> BNC connectors ( <b>SET 3</b> )	SET 3 of 5 amplified buffered and clamped video outputs.
7.	<b>OUT 1-5</b> BNC connectors ( <b>SET 4</b> )	SET 4 of 5 amplified buffered and clamped video outputs.
8.	Power Connector	A 3-prong AC connector allows power to be supplied to the unit. Directly underneath this connector, a fuse holder houses the appropriate fuse.



## 5.4 Getting To Know Your VM-1042 Amplifier

The KRAMER VM-1042 is a full broadcast, looping Video Component Distributor designed for studio and other demanding applications. VM-1042 splits each input of a four-component source into two identical outputs with no discernible signal degradation. Input and output DC coupling and state-of-the-art video amplifying circuitry make the KRAMER VM-1042 the first choice Video Component Distributor. Signal bandwidth of 200MHz allows the VM-1042 to be used for the most demanding applications. The VM-1042 may be used as a 4 times looping 1:2 video DA of exceptional quality, for any video source (Composite, YC, YUV or RGB).

Front/rear panel features of the VM-1042 are described in Figure 4 and Table 7.

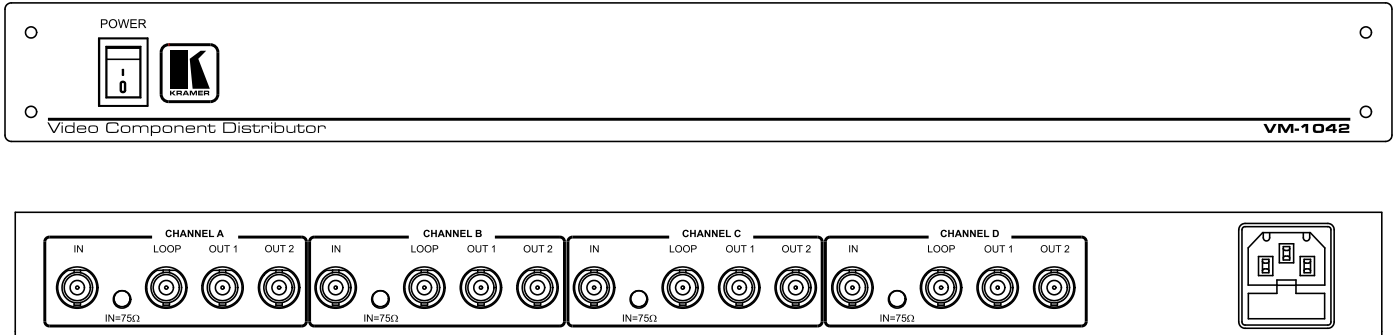

Figure 4: VM-1042 Front/Rear Panel Features

Table 7: VM-1042 Front/Rear Panel Features

No.	Feature	Function
1.	Power Switch (front panel)	Illuminated switch: Supplies power to the unit.
2.	<b>IN</b> BNC connector (CHANNELS A, B, C, D)	Channel video input.
3.	<b>TERM</b> pushbutton (CHANNELS A, B, C, D)	Selects “75Ω” or “Hi-z” impedance for channel A when pressed (for looping select “Hi-z”).
4.	<b>LOOP</b> BNC connector (CHANNELS A, B, C, D)	Provides video looping capability to increase number of outputs.
5.	<b>OUT 1,2</b> BNC connectors (CHANNELS A, B, C, D)	Channel amplified and buffered video outputs.
6.	Power Connector (back panel)	A 3-prong AC connector allows power to be supplied to the unit. Directly underneath this connector, a fuse holder houses the appropriate fuse.



## 5.5 Getting To Know Your VM-1044 Amplifier

The KRAMER VM-1044 is a full broadcast, Video Component Distributor designed for studio and other demanding applications. The VM-1044 splits a four-component input source into four identical outputs, with no discernible signal degradation. Input and output DC coupling and state-of-the-art video amplifying circuitry make the KRAMER VM-1044 the first choice Video Component Distributor. Signal bandwidth of over 320MHz allows the VM-1044 to be used with graphics workstations. The VM-1044 may serve as a 4 times 1:4 Video DA of exceptional quality, for any video source (Composite, YC, YUV, RGB and SDI).

Front/rear panel features of the VM-1044 are described in Figure 5 and Table 8.

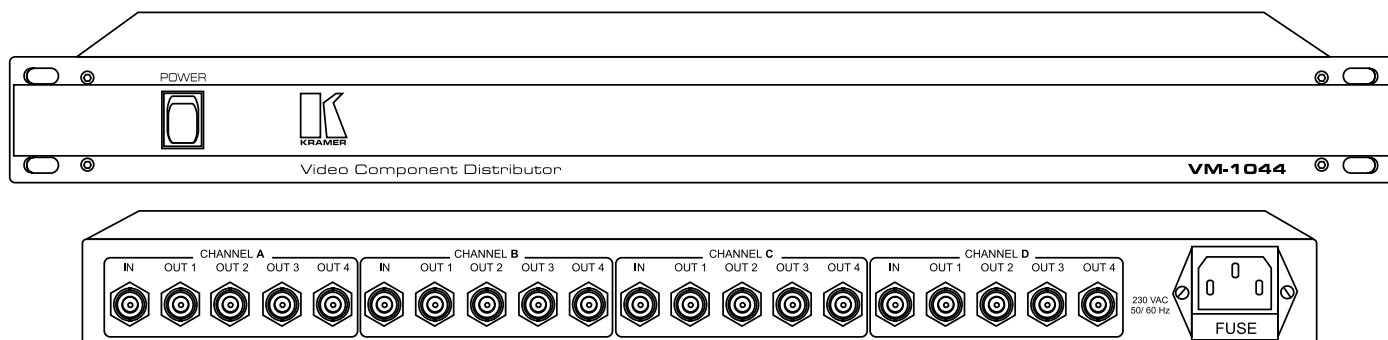

Figure 5: VM-1044 Front/Rear Panel Features

Table 8: VM-1044 Front/Rear Panel Features

No.	Feature	Function
1.	Power Switch (front panel)	Illuminated switch: Supplies power to the unit.
2.	IN BNC connector (CHANNEL A, B, C, D)	Channel video input.
3.	OUT 1- 4 BNC connectors (CHANNEL A, B, C, D)	Channel amplified and buffered video outputs.
4.	Power Connector	A 3-prong AC connector allows power to be supplied to the unit. Directly underneath this connector, a fuse holder houses the appropriate fuse.

## 5.6 Getting To Know Your VM-1055 Amplifier

The KRAMER VM-1055 is a full broadcast, Video Component/RGBHV Distributor designed for studio, graphics workstation, presentation and other demanding applications. The VM-1055 splits a five-component input source into five identical outputs, with no discernible signal degradation. DC coupled inputs and outputs and state-of-the-art video amplifying circuitry make the KRAMER VM-1055 the first choice Video Component Distributor. Signal bandwidth of over 300 MHz and the option to adjust the termination of two "sync" channels (75  $\Omega$ s analog or TTL level) allow the VM-1055 to be used with graphics workstations and for presentation purposes. The VM-1055 may function as a 5 X 1:5 Video DA, for any video source when the termination switch is at "75 $\Omega$ " (Composite, YC, YUV, RGB and SDI); or as a three analog channels and two TTL channel distributor. Front/rear panel features of the VM-1055 are described in Figure 6 and Table 9.

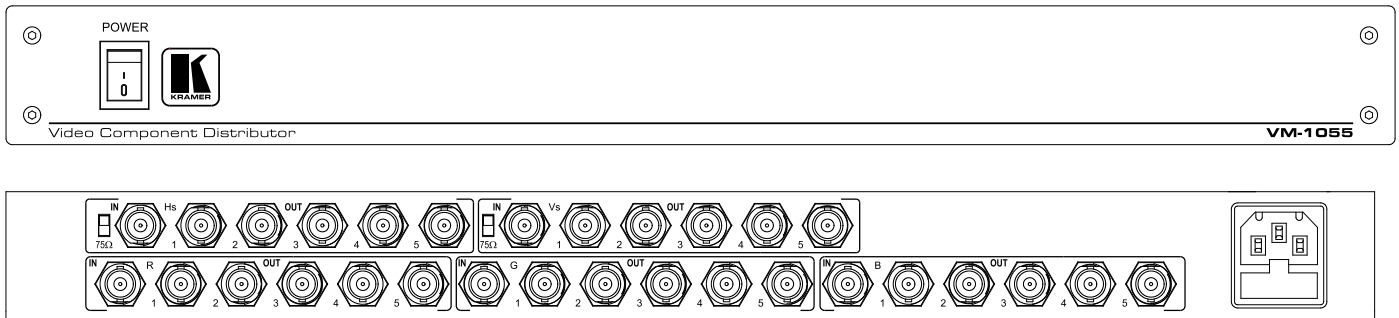

**Figure 6: VM-1055 Front/Rear Panel Features**

**Table 9: VM-1055 Front/Rear Panel Features**

No.	Feature	Function
1.	Power switch	Illuminated switch: Supplies power to the unit.
2.	75Ω switch	Selects “75Ω” or “HI-Z” impedance for Hs Channel. When at the “75Ω” position, the signal applied to the connector should be analog video or sync signal. When in the “HI-Z” position a TTL level sync signal may be used.
3.	IN Hs BNC connector	Hs Channel video input (horizontal sync).
4.	OUT Hs 1- 5 BNC connectors	Hs Channel amplified and buffered video outputs.
5.	75Ω switch	Selects “75Ω” or “HI-Z” impedance for Vs Channel. When at the “75Ω” position, the signal applied to the connector should be analog video or sync signal. When in the “HI-Z” position a TTL level sync signal may be used.
6.	IN Vs BNC connector	Vs Channel video input (vertical sync).
7.	OUT Vs 1- 5 BNC connectors	Vs Channel amplified and buffered video outputs that are identical to each other and to the input.
8.	IN R BNC connector	R Channel video input.
9.	OUT R 1-5 impedance for Vs Channel.	R Channel amplified and buffered video outputs that are identical to each other and to the input.
10.	IN G BNC connector	G Channel video input.
11.	OUT G 1-5 BNC connectors	G Channel amplified and buffered video outputs that are identical to each other and to the input.
12.	IN B BNC connector	B Channel video input.
13.	OUT B 1-5 BNC connectors	B Channel amplified and buffered video outputs that are identical to each other and to the input.
14.	Power Connector	A 3-prong AC connector allows power to be supplied to the unit. Directly underneath this connector, a fuse holder houses the appropriate fuse.



## 5.7 Getting To Know Your VM-54 Amplifier

The KRAMER VM-54 is a high quality, state-of-the-art, Video/Component Distribution Amplifier designed for studio and other demanding applications. The VM-54 has three looping input channels each with 18 outputs. With this configuration a 1:18 RGB distributor can be formed. Each channel is subdivided into four groups of five or three outputs, which may be tuned separately for gain and cable EQ. The three input channels may be looped-through together to form a 1:54 DA, or other configurations (e.g. 1:18 Composite or 1:18 YC - using two channels). To form a 1:54 distributor, the channel 1 LOOP connector should be connected to the input connector of channel 2. The channel 2 LOOP connector should be connected to the input connector of channel 3. The termination switches of channels 1 and 2 should be set at "Hi-z" and the channel 3 termination switch should be set to "75Ω". Output signals may be AC or DC coupled via front panel controls. Signal bandwidth exceeding 350 MHz makes the VM-54 the first choice for a large video/component distribution center.

Front/rear panel features of the VM-54 are described Figure 7, Table 10 and Table 11.

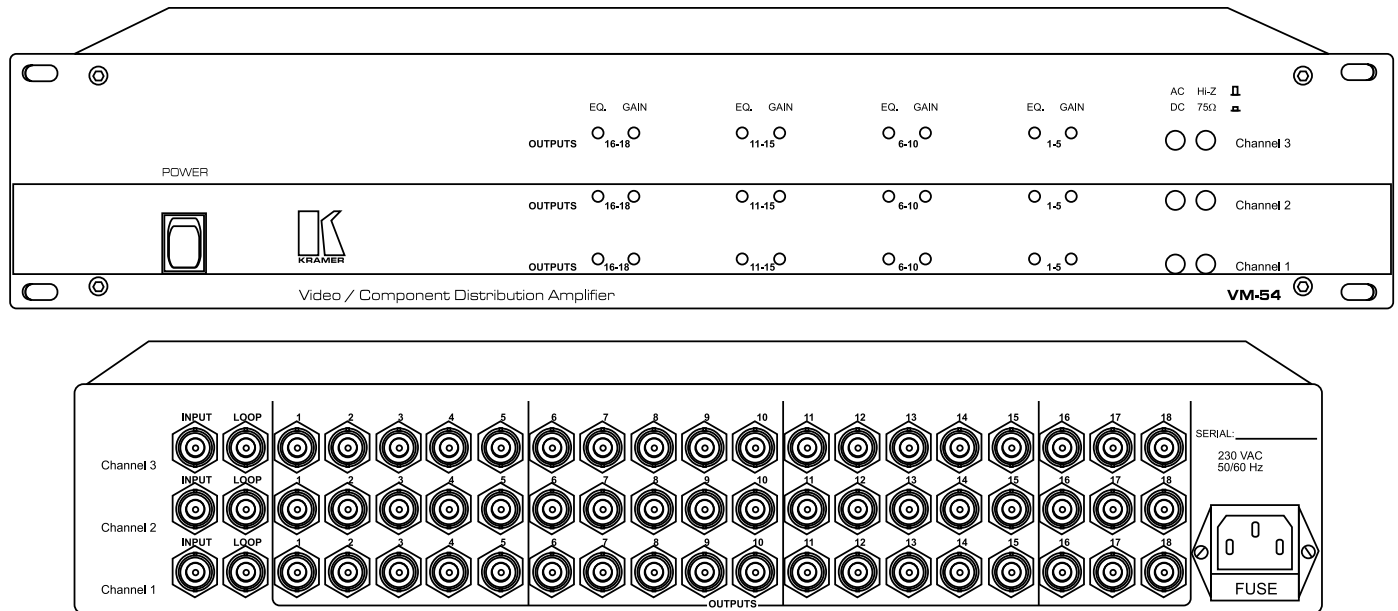

Figure 7: VM-54 Front/Rear Panel Features

Table 10: VM-54 Front Panel Features

No.	Feature	Function
1.	Power Switch	Illuminated switch: Supplies power to the unit.
2.	<b>EQ trimmers (OUTPUTS 16-18, Channels 1-3)</b>	Controls cable equalization of video outputs 16-18 in Channels 1-3.
3.	<b>GAIN trimmers (OUTPUTS 16-18, Channels 1-3)</b>	Controls video levels of outputs 16-18 in Channels 1-3.
4.	<b>EQ trimmers (OUTPUTS 11-15, Channels 1-3)</b>	Controls cable equalization of video outputs 11-15 in Channels 1-3.
	<b>GAIN trimmers (OUTPUTS 11-15, Channels 1-3)</b>	Controls video levels of outputs 11-15 in Channels 1-3.
5.	<b>EQ trimmers (OUTPUTS 6-10, Channels 1-3)</b>	Controls cable equalization of video outputs 6-10 in Channels 1-3.



No.	Feature	Function
6.	<b>GAIN</b> trimmers ( <b>OUTPUTS 6-10, Channels 1-3</b> )	Controls video levels of outputs 6-10 in Channels 1-3.
7.	<b>EQ</b> trimmers ( <b>OUTPUTS 1-5, Channels 1-3</b> )	Controls cable equalization of video outputs 1-5 in Channels 1-3.
8.	<b>GAIN</b> trimmers ( <b>OUTPUTS 1-5, Channels 1-3</b> )	Controls video levels of outputs 1-5 in Channels 1-3.
9.	<b>AC/DC</b> switches ( <b>Channels 1-3</b> )	Selects AC/DC coupling for Channels 1-3 (DC coupling when pressed).
10.	<b>Hi-Z/75Ω</b> switches( <b>Channels 1-3</b> )	Selects “ <b>Hi-Z/75Ω</b> ” impedance for Channels 1-3 (75 Ω termination is applied when pressed).

**Table 11: VM-54 Rear Panel Features**

No.	Feature	Function
1.	<b>INPUT</b> BNC connectors ( <b>channels 1-3</b> )	Video input (channels 1-3).
2.	<b>LOOP</b> BNC connectors ( <b>channels 1-3</b> )	Provides video looping capability to increase number of outputs (channels 1-3).
3.	<b>OUTPUTS</b> BNC connectors <b>1-18 (channels 1-3)</b>	Video outputs that are identical to each other and to the input.
4.	Power Connector	A 3-prong AC connector allows power to be supplied to the unit. Directly underneath this connector, a fuse holder houses the appropriate fuse.

## 6. INSTALLATION

### 6.1 Rack Mounting

#### Before Installing on a Rack

Before installing on a rack, be sure that the environment is within the recommended range:	
Operating temperature range	+5 to +45 Deg. Centigrade
Operating humidity range	10 to 90% RHL, non-condensing
Storage temperature range	-20 to +70 Deg. Centigrade
Storage humidity range	5 to 95% RHL, non-condensing



#### CAUTION!!

When installing on a 19" rack, avoid hazards by taking care that:

- 1 It is located within the recommended environmental conditions, as the operating ambient temperature of a closed or multi unit rack assembly may exceed the room ambient temperature.
- 2 Once rack mounted, enough air will still flow around the machine.
- 3 The machine is placed straight in the correct horizontal position.
- 4 You do not overload the circuit(s). When connecting the machine to the supply circuit, overloading the circuits might have a detrimental effect on overcurrent protection and supply wiring. Refer to the appropriate nameplate ratings for information. For example, for fuse replacement, see the value printed on the product label.
- 5 The machine is earthed (grounded) in a reliable way and is connected only to an electricity socket with grounding. Pay particular attention to situations where electricity is supplied indirectly (when the power cord is not plugged directly into the socket in the wall), for example, when using an extension cable or a power strip, and that you use only the power cord that is supplied with the machine.

#### How to Rack Mount

To rack-mount a machine:

- 1 Attach both ear brackets to the machine. To do so, remove the screws from each side of the machine (3 on each side), and replace those screws through the ear brackets.

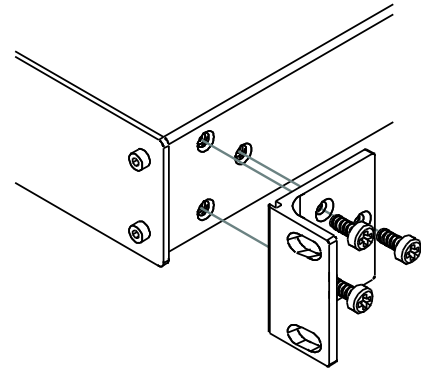

- 2 Place the ears of the machine against the rack rails, and insert the proper screws (not provided) through each of the four holes in the rack ears.

Note that:

- In some models, the front panel may feature built-in rack ears
- Detachable rack ears can be removed for desktop use
- Always mount the machine in the rack before you attach any cables or connect the machine to the power
- If you are using a Kramer rack adapter kit (for a machine that is not 19"), see the Rack Adapters user manual for installation instructions (you can download it at: <http://www.kramerelectronics.com>)



## 7. CONNECTING TO VIDEO DEVICES

Video sources and output devices (such as monitors, projectors or recorders) may be connected to the amplifiers through the BNC type connectors located on the back of the units. Unused inputs are terminated to  $75\Omega$ , and active inputs should be terminated at the connecting source. Please keep in mind that the output signal format will match that of the input signal format. (Example: If input is composite, then output is composite.) All signal connections that use more than one cable interconnecting between devices should be of equal length. (Example: R,G,B cables between a camera and the amplifier should be equal in length.) The signals supported by the various models are described in Table 12.

**Table 12: Signals Supported By Model**

No.	Model	Supported signal
1.	VM-1010	Composite/component/YC/analog sync video
2.	VM-1015	Composite/component/ analog sync video
3.	VM-1021	Composite/component/ analog sync video
4.	VM-1042	Composite/RGBs/component
5.	VM-1044	Composite/RGBs/component
6.	VM-1055	Composite/RGBHsVs/ analog or TTL sync component
7.	VM-54	Composite/component RGBs video

## 8. USING THE VIDEO AMPLIFIERS

### 8.1 Powering On The Amplifier

#### NOTES

1. *The amplifier should only be powered on, after all connections are completed, and all source devices have been powered on. Do not attempt to connect or disconnect any video, audio or control signals to the amplifier while it is powered on!*
2. *The socket-outlet should be near the equipment and should be easily accessible. To fully disconnect equipment, remove power cord from its socket.*

- 1) Press the toggle switch on the far-left front panel to the up position. In the up position, the toggle switch glows red, and the active input button illuminates, as well.
- 2) Operate the acceptors.

### 8.2 Looping

The looping function enables the operator to extend the number of outputs per input. The following example describes looping performed by using three amplifiers with one input and five outputs each: A video signal reaches input of amplifier No. 1. From looping connector of amplifier No. 1 a cable is connected to input socket of amplifier No. 2. The loop output of amplifier No. 2 is connected to the input socket of amplifier No. 3. By this way the input signal is divided into 15 separate output signals. The operator must always switch to "Hi-z" the termination switch of all the amplifiers but the last. The last amplifier's termination switch should always be at " $75\Omega$ " to maintain well-matched video

line (of 75Ω impedance) from first to last amplifier. Note that if looping function is not used, the termination switch should be set to "75 Ω".

### 8.3 Level Control

(VM-1010, VM-1015, VM-1021, VM-54 only)

Level Control function enables the operator to control video signal level or compensate for distortions such as those caused by cables that are too long. Using a non-standard, or an uncalibrated video source also affects the incoming signal. Picture darkness is usually caused by low video signal and on the other hand, excessive video level "burns" the picture. The sync signal (approx. -0.3v) may be used to check conformity of the whole video signal: If sync level is too low or too high, the incoming video signal is not within the standard level. To correct the incoming video signal, an oscilloscope should be connected to amplifier's output and the LEVEL trimmer adjusted until satisfactory sync level and hence proper picture are achieved.

#### WARNING!

1. *Be aware that the amplifier was pre-calibrated for transparent operation at the factory and re-tuning it will upset signal transparency.*
2. *Do not attempt to adjust the LEVEL trimmers without using accompanying standard calibrated oscilloscope or waveform monitor!*

### 8.4 Equalization Control

(VM-1010, VM-1015, VM-1021, VM-54 only)

Equalization Control function enables the operator to compensate for degradation of the video signal due to too long or non-standard cables. Popular cables such as the RG-59, RG-11 or the RG-179 signal cause degradation/attenuation of the following values:

CABLE TYPE	LENGTH	FREQUENCY	ATTENUATION
RG-59	100 meter	10MHz	3.6dB
	100 meter	100MHz	11dB
RG-11	100 meter	10MHz	2.2dB
	100 meter	100MHz	7.5dB
RG-179	100 meter	10MHz	8dB
	100 meter	100MHz	30dB

Degradation and loss of video signal are mainly caused due to stray capacitance which occur in long cables. As longer cables or higher frequency are used, the problem becomes worse, resulting in fine detail loss as well as color degradation. When RGB signals are involved (200-300MHz), degradation is even greater, leading to a total loss of sharpness at high resolution. It is necessary to compensate for the problem by using the amplifier's EQ. Control trimmer. Equalization is performed as follows: A Color Bar Generator is connected to amplifier's input and a Waveform Monitor (or an Oscilloscope with 75 Ω termination) is connected to the long cable output. A known color bar signal is applied to the amplifier's input and compared to the signal monitored at the far side. The operator adjusts the EQ. trimmer until the measured output chrominance signal matches that of the input signal.

### WARNING!

1. *The amplifier was calibrated at the factory for transparent operation at 1 meter. Any re-tuning will upset amplifier's transparency.*
2. *Do not attempt to adjust the Equalization trimmers without using accompanying standard calibrated oscilloscope or waveform monitor!*

## 8.5 Coupling

The coupling function enables the operator to determine whether the incoming video signal is DC or AC coupled. When DC coupling is selected and proper standard video signal is applied to the amplifier's input, the output signal is equal to the input signal. When AC coupling is selected, DC components of the incoming signal are removed. DC coupling is always preferable since AC coupling might cause some linearity distortions in low and high frequencies (due to non-ideal behavior of capacitors). A problem may arise when the incoming signal is riding on a DC offset especially when the acceptors are highly effected by deviation of DC offsets (A/D converters for example), which in turn results in a distorted picture.

## 8.6 Black Level Clamping

(VM-1015, VM-1021 only)

In the Black Level Clamping process, the incoming black level signal is "clamped" to "zero". Whenever this process is activated (by pressing the "BLACK" pushbutton), the amplifier's internal system automatically switches to AC coupling, thus removing the original DC components of the incoming signal. The black level is clamped to "zero", thus converting the input signal to a standard video signal. Whenever the picture is distorted, too dark or too bright the DC offset is probably responsible so it is recommended to choose AC coupling. If the malfunction still exists, the "BLACK" pushbutton should be activated to restore the standard DC level of the video signal.

## 8.7 Sync Tip Clamping

(VM-1015, VM-1021 only)

Sync Tip Clamping is recommended for video signals such as RGB. The RGB signal maximum amplitude is between 0.7V DC to 1V DC and their bottom level should be always clamped to "zero". It sometimes contains sync signal ("sync on green") and sometimes does not. When the Sync Tip Clamping process is activated (by pressing the "Sync Tip" pushbutton), signal bottom level is clamped to "zero" and the whole video signal is now positive and "zero" clamped.

## 9. TAKING CARE OF YOUR VIDEO AMPLIFIER

Do not locate your amplifier in an environment where it is susceptible to dust or moisture. These may damage the electronics, and cause erratic operation or failure. Do not locate your amplifier where temperature and humidity may be excessive. Do not clean your amplifier with abrasives or strong cleaners. Doing so may remove or damage the finish, or may allow moisture to build up. Take care not to allow dust or particles to build up inside unused or open connectors.



## 10. TROUBLESHOOTING

### NOTES

1. Please note that if the output signal is disturbed or interrupted by very strong external electromagnetic interference, it should return and stabilize when such interference ends. If not, turn the power switch off and on again to reset the machine.
2. If the recommended actions still do not result in satisfactory operation, please consult your KRAMER Dealer.

### 10.1 Power and Indicators

Problem	Remedy
No Power	<ol style="list-style-type: none"><li>1. Confirm that rocker switch is in “ON” position, and red LED is illuminated.</li><li>2. Confirm that power connections are secured at the amplifier and at the receptacle. Make sure the receptacle is active, outputting the proper mains voltage.</li><li>3. If there is still no power, check the fuse. Remove power cord from the AC outlet and from the machine and then, using a flat head screwdriver, remove the fuse holder located directly below the power connector. Confirm that the fuse is good by looking at the wire connected to the ends of the fuse. If the wire is broken, replace the fuse with another, with the same value.</li></ol>

### 10.2 Video Signal

Problem	Remedy
No video at the output device, regardless of input selected.	<ol style="list-style-type: none"><li>1. Confirm that your sources and output device are powered on and connected properly. Video signals at the input of your amplifier should be of an identical signal format at the output of your source. Video signals at the output of your amplifier should be of an identical signal format as at the input of your display or recorder.</li><li>2. Confirm that any other amplifiers in the signal path have the proper input and/or output selected.</li><li>3. Use a Video Tester to test the video path leading to/from your amplifier.</li></ol>
Video level is too high or too dim.	<ol style="list-style-type: none"><li>1. The amplifiers in this manual (except for the VM-1044 and VM-54) have termination switches on each input. Verify that the video line is well matched through 75 <math>\Omega</math> impedance, otherwise it results in a video level that is too high or too dim when looping is performed and the termination switches are not in proper position.</li><li>2. Confirm that the connecting cables are of high quality, properly built and terminated with 75<math>\Omega</math> BNC connectors. Check level controls located on your source input device or output display or recorder.</li></ol>

Problem	Remedy
<p>Noise bars "roll" up or down in the output image</p> <p>or:</p> <p>Low frequency hum in the output signal</p>	<p>Hum bars (ground loop) are caused by a difference in the ground potential of any two or more devices connected to your signal path. This voltage difference passes through any available interconnection, including your video cables.</p> <p style="text-align: center;"><b>WARNING!</b></p> <p style="text-align: center;"><b><i>Do not disconnect the ground from any piece of video equipment in your signal path!</i></b></p> <p>Check the following to remove hum bars:</p> <ol style="list-style-type: none"><li>1. Confirm that all interconnected equipment is connected to the same phase of power, if possible.</li><li>2. Remove equipment connected to the phase that may be introducing noise, such as motors, generators, etc.</li><li>3. Disconnect all cables and reconnect them one at a time until ground loop reappears. Disconnect the affected cable and replace, or insert an isolation device (opto isolator or transformer) in the signal path.</li></ol>



## LIMITED WARRANTY

Kramer Electronics (hereafter *Kramer*) warrants this product free from defects in material and workmanship under the following terms.

### HOW LONG IS THE WARRANTY

Labor and parts are warranted for seven years from the date of the first customer purchase.

### WHO IS PROTECTED?

Only the first purchase customer may enforce this warranty.

### WHAT IS COVERED AND WHAT IS NOT COVERED

Except as below, this warranty covers all defects in material or workmanship in this product. The following are not covered by the warranty:

1. Any product which is not distributed by Kramer, or which is not purchased from an authorized Kramer dealer. If you are uncertain as to whether a dealer is authorized, please contact Kramer at one of the agents listed in the Web site [www.kramerelectronics.com](http://www.kramerelectronics.com).
2. Any product, on which the serial number has been defaced, modified or removed, or on which the WARRANTY VOID IF TAMPERED sticker has been torn, reattached, removed or otherwise interfered with.
3. Damage, deterioration or malfunction resulting from:
  - i) Accident, misuse, abuse, neglect, fire, water, lightning or other acts of nature
  - ii) Product modification, or failure to follow instructions supplied with the product
  - iii) Repair or attempted repair by anyone not authorized by Kramer
  - iv) Any shipment of the product (claims must be presented to the carrier)
  - v) Removal or installation of the product
  - vi) Any other cause, which does not relate to a product defect
  - vii) Cartons, equipment enclosures, cables or accessories used in conjunction with the product

### WHAT WE WILL PAY FOR AND WHAT WE WILL NOT PAY FOR

We will pay labor and material expenses for covered items. We will not pay for the following:

1. Removal or installations charges.
2. Costs of initial technical adjustments (set-up), including adjustment of user controls or programming. These costs are the responsibility of the Kramer dealer from whom the product was purchased.
3. Shipping charges.

### HOW YOU CAN GET WARRANTY SERVICE

1. To obtain service on you product, you must take or ship it prepaid to any authorized Kramer service center.
2. Whenever warranty service is required, the original dated invoice (or a copy) must be presented as proof of warranty coverage, and should be included in any shipment of the product. Please also include in any mailing a contact name, company, address, and a description of the problem(s).
3. For the name of the nearest Kramer authorized service center, consult your authorized dealer.

### LIMITATION OF IMPLIED WARRANTIES

All implied warranties, including warranties of merchantability and fitness for a particular purpose, are limited in duration to the length of this warranty.

### EXCLUSION OF DAMAGES

The liability of Kramer for any effective products is limited to the repair or replacement of the product at our option. Kramer shall not be liable for:

1. Damage to other property caused by defects in this product, damages based upon inconvenience, loss of use of the product, loss of time, commercial loss; or:
2. Any other damages, whether incidental, consequential or otherwise. Some countries may not allow limitations on how long an implied warranty lasts and/or do not allow the exclusion or limitation of incidental or consequential damages, so the above limitations and exclusions may not apply to you.

This warranty gives you specific legal rights, and you may also have other rights, which vary from place to place.

**NOTE:** All products returned to Kramer for service must have prior approval. This may be obtained from your dealer.

This equipment has been tested to determine compliance with the requirements of:

- EN-50081: "Electromagnetic compatibility (EMC);  
generic emission standard.  
Part 1: Residential, commercial and light industry"
- EN-50082: "Electromagnetic compatibility (EMC) generic immunity standard.  
Part 1: Residential, commercial and light industry environment".
- CFR-47: FCC Rules and Regulations:  
Part 15: "Radio frequency devices  
Subpart B Unintentional radiators"

### CAUTION!

- ☒ Servicing the machines can only be done by an authorized Kramer technician. Any user who makes changes or modifications to the unit without the expressed approval of the manufacturer will void user authority to operate the equipment.
- ☒ Use the supplied DC power supply to feed power to the machine.
- ☒ Please use recommended interconnection cables to connect the machine to other components.



---

**For the latest information on our products and a list of  
Kramer distributors, visit our Web site:  
[www.kramerelectronics.com](http://www.kramerelectronics.com)  
where updates to this user manual may be found.  
We welcome your questions, comments and feedback.**



---

**Kramer Electronics, Ltd.**

Web site: [www.kramerelectronics.com](http://www.kramerelectronics.com)

E-mail: [info@kramerel.com](mailto:info@kramerel.com)

P/N: 2900-001001 REV 4