

Kramer Electronics, Ltd.



USER MANUAL

Model:

TP-210A

UXGA – Audio – RS-232 Line Transmitter/DA

Contents

1	Introduction	1
2	Getting Started	1
2.1	Quick Start	2
3	Overview	3
3.1	About the Power Connect Feature	3
3.2	Shielded Twisted Pair (STP)/Unshielded Twisted Pair (UTP)	4
3.3	Recommendations for Achieving the Best Performance	4
4	Your TP-210A UXGA – Audio – RS-232 Line Transmitter/DA	4
4.1	The TP-210A UXGA – Audio – RS-232 Line Transmitter/DA Underside	6
5	Installing on a Rack	7
6	Connecting the TP-210A	8
6.1	Wiring the CAT 5 LINE IN/LINE OUT RJ-45 Connectors	10
6.2	Wiring the RS-232 Connector	10
7	Technical Specifications	11

Figures

Figure 1:	TP-210A UXGA – Audio – RS-232 Line Transmitter/DA	5
Figure 2:	TP-210A Underside	6
Figure 3:	Connecting the TP-210A UXGA – Audio – RS-232 Line Transmitter/DA	9
Figure 4:	CAT 5 PINOUT	10
Figure 5:	RS-232 PINOUT Connection	10

Tables

Table 1:	TP-210A UXGA – Audio – RS-232 Line Transmitter/DA Features	6
Table 2:	Features of the TP-210A Underside	6
Table 3:	CAT 5 PINOUT	10
Table 4:	Technical Specifications of the TP-210A	11

1 Introduction

Welcome to Kramer Electronics! Since 1981, Kramer Electronics has been providing a world of unique, creative, and affordable solutions to the vast range of problems that confront the video, audio, presentation, and broadcasting professional on a daily basis. In recent years, we have redesigned and upgraded most of our line, making the best even better! Our 1,000-plus different models now appear in 11 groups¹ that are clearly defined by function.

Thank you for purchasing the Kramer **TP-210A UXGA – Audio – RS-232 Line Transmitter/DA**, which is ideal for:

- Presentation and multimedia applications
- Long range graphics distribution for schools, hospitals, security, and stores

The package includes the following items:

- **TP-210A UXGA – Audio – RS-232 Line Transmitter/DA**
- Power cord²
- This user manual³

2 Getting Started

We recommend that you:

- Unpack the equipment carefully and save the original box and packaging materials for possible future shipment
- Review the contents of this user manual
- Use Kramer high performance high-resolution cables⁴

1 GROUP 1: Distribution Amplifiers; GROUP 2: Switchers and Matrix Switchers; GROUP 3: Control Systems; GROUP 4: Format/Standards Converters; GROUP 5: Range Extenders and Repeaters; GROUP 6: Specialty AV Products; GROUP 7: Scan Converters and Scalers; GROUP 8: Cables and Connectors; GROUP 9: Room Connectivity; GROUP 10: Accessories and Rack Adapters; GROUP 11: Sierra Products

2 We recommend that you use only the power cord supplied with this device

3 Download up-to-date Kramer user manuals from our Web site at <http://www.kramerelectronics.com>

4 The complete list of Kramer cables is on our Web site at <http://www.kramerelectronics.com>

2.1 Quick Start

The quick start chart summarizes the basic setup and operation steps of the TP-210A.

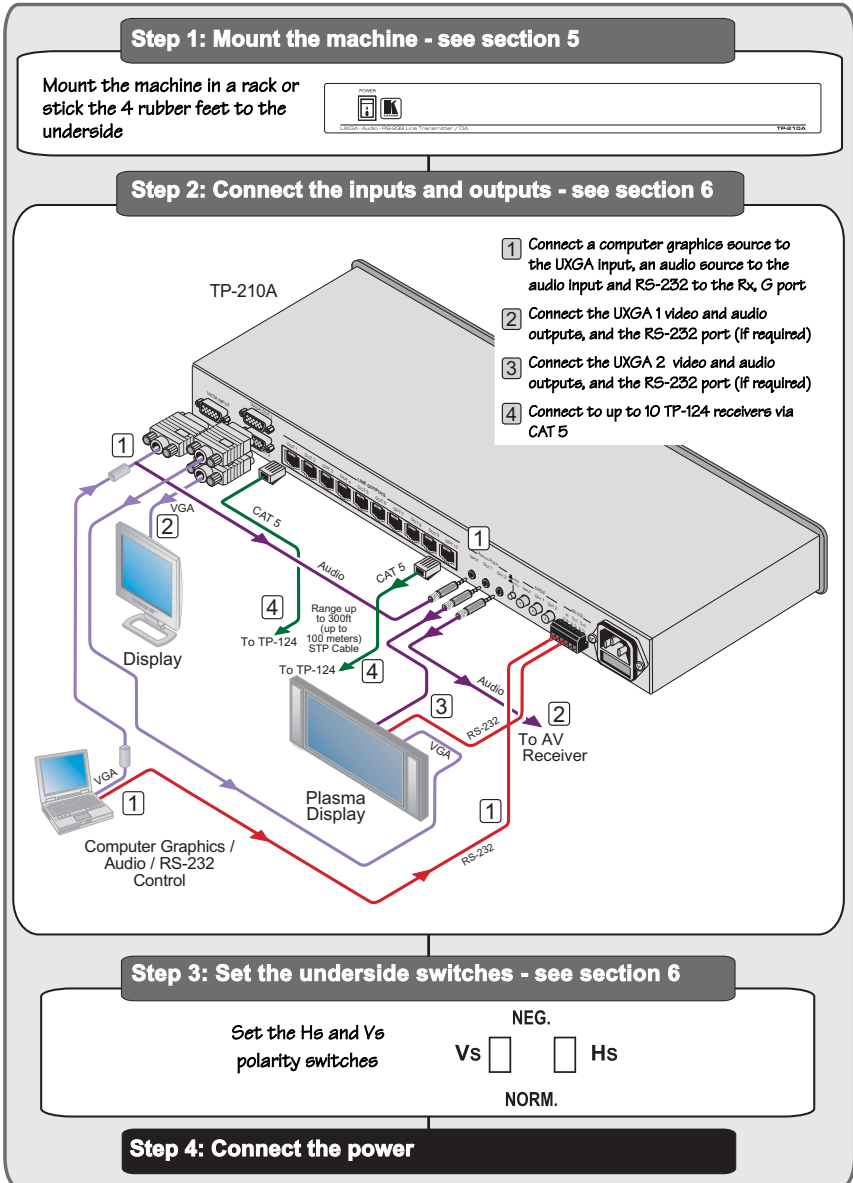

3 Overview

The **TP-210A UXGA – Audio – RS-232 Line Transmitter/DA** receives a computer graphics signal, an audio signal¹ and an RS-232 signal, and distributes them to up to 10 receivers (via CAT 5 cables). The **TP-210A** also simultaneously distributes the signal to two UXGA outputs, two analog audio outputs or two digital audio outputs, and two RS-232 outputs.

The **TP-210A** serves as a power center that can distribute power to the connected receivers (see section [3.1](#)).

In particular, the **TP-210A** features:

- A resolution of up to UXGA
- One UXGA input and two outputs on 15-pin HD computer graphics video connectors
- One digital audio input and two outputs (S/PDIF) on RCA connectors as well as one analog audio input and two outputs on 3.5mm mini jacks
- A transmission range of up to 300ft (up to 100 meters) over STP cabling
- Changeable polarity for decoding H and V Sync for video (UXGA)

The **TP-210A** is housed in a 19" 1U rack mountable enclosure, with rack “ears” included, and is fed from a 100-240V AC universal switching power supply.

3.1 About the Power Connect Feature

The Power Connect feature applies as long as the cable can carry power. This feature is available when using STP cable and the distance does not exceed 50m on standard CAT 5 cable. For longer distances, heavy gauge cable should be used². For units which are connected via RJ-45 connectors, make sure that the shield of the STP cable is connected to the metal casing of the connectors on both ends of the cable. For units which are connected via terminal block connectors, the shield of the STP cable must be connected to a ground terminal on the units at both ends (use the ground terminal of the power supply connection if necessary).

For a CAT 5 cable exceeding a distance of 50m, separate power supplies should be connected to the transmitter and to the receiver simultaneously.

¹ Selectable analog or digital (S/PDIF) audio signal

² CAT 5 cable is still suitable for the video/audio transmission, but not for feeding the power at these distances

3.2 Shielded Twisted Pair (STP)/Unshielded Twisted Pair (UTP)

We recommend that you use Shielded Twisted Pair (STP) cable. There are different levels of STP cable available, and we advise you to use the best quality STP cable that you can afford. Our non-skew-free cable, Kramer **BC-STP** is intended for analog signals where skewing is not an issue. For cases where there is skewing, our UTP skew-free cable, Kramer **BC-XTP**, may be used. Bear in mind, though, that we advise using STP cables where possible, since the compliance to electromagnetic interference was tested using those cables.

Although Unshielded Twisted Pair (UTP) cable might be preferred for long range applications, the UTP cable should be installed far away from electric cables, motors and so on, which are prone to create electrical interference. However, since the use of UTP cable might cause inconformity to electromagnetic standards, Kramer does not commit to meeting the standard with UTP cable.

3.3 Recommendations for Achieving the Best Performance

To achieve the best performance:

- Use only good quality connection cables¹ to avoid interference, deterioration in signal quality due to poor matching, and elevated noise levels (often associated with low quality cables).
- Avoid interference from neighboring electrical appliances that may adversely influence signal quality and position your Kramer **TP-210A** away from moisture, excessive sunlight and dust

4 Your TP-210A UXGA – Audio – RS-232 Line Transmitter/DA

[Figure 1](#) and [Table 1](#) define the **TP-210A**:

¹ Available from Kramer Electronics on our Web site at <http://www.kramerelectronics.com>

Your TP-210A UXGA – Audio – RS-232 Line Transmitter/DA

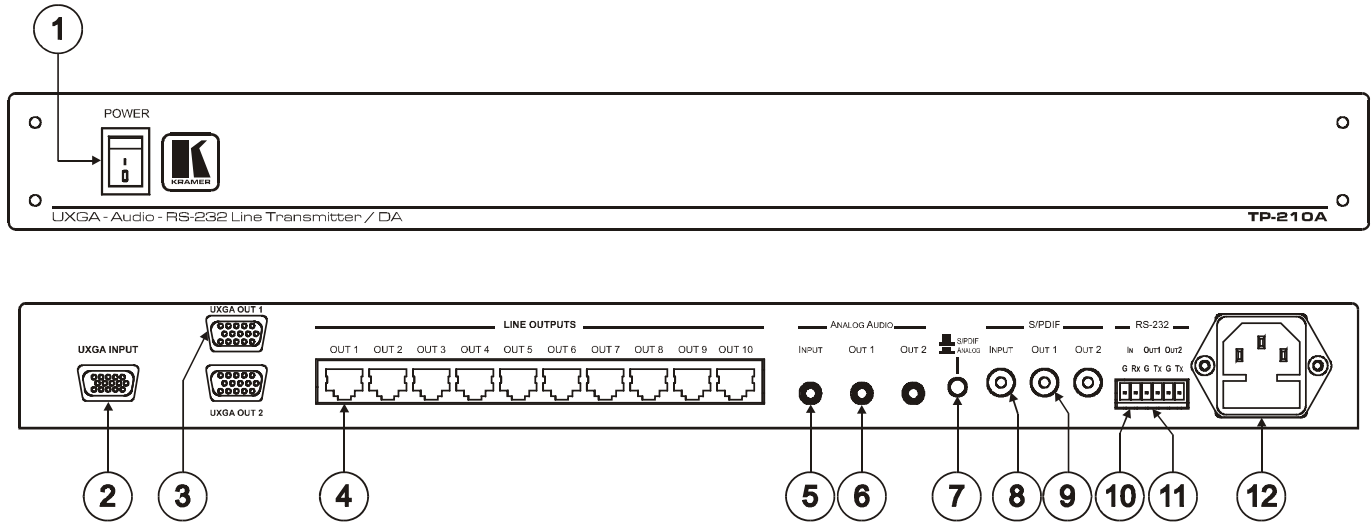

Figure 1: TP-210A UXGA – Audio – RS-232 Line Transmitter/DA

Table 1: TP-210A UXGA – Audio – RS-232 Line Transmitter/DA Features

#	Feature		Function
1	POWER Switch		Illuminated switch for turning the unit ON or OFF
2	UXGA INPUT 15-pin HD Connector		Connect to the video source
3	UXGA OUT 15-pin HD Connectors		Connect to the video acceptor ¹
4	LINE OUTPUT RJ-45 Connectors ¹		Connect to ² the LINE IN RJ-45 connector on a receiver ³
5	ANALOG AUDIO	INPUT	Connect to the stereo analog audio source
6	3.5mm Mini Jacks	OUT	Connect to the stereo analog audio acceptor ¹
7	S/PDIF ANALOG Selector Button ⁴		Press to select the analog audio source Release to select the S/PDIF source
8	S/PDIF RCA	INPUT	Connect to the digital audio source
9	Connectors	OUT	Connect to the digital audio acceptor ¹
10	RS-232 Terminal Block Connector	IN (G, Rx)	Connect the two connectors (G and Rx) to transmit a command (see section 6.1)
11		OUT (G, Tx ¹)	Connect the two connectors (G and Tx) to control a device (see section 6.1)
12	Power Connector with Fuse		AC connector enabling power supply to the unit

4.1 The TP-210A UXGA – Audio – RS-232 Line Transmitter/DA Underside

Figure 2 and Table 2 define the underside of the TP-210A

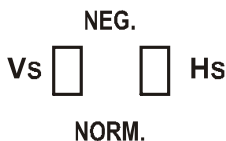

Figure 2: TP-210A Underside

Table 2: Features of the TP-210A Underside

Feature	Function
VS Switch ⁵	Slide the switch up, to set the VS to negative polarity (NEG.) Slide the switch down, to set the VS to its input polarity (NORM.)
HS Switch ⁵	Slide the switch up, to set the HS to negative polarity (NEG.) Slide the switch down, to set the HS to its input polarity (NORM.)

¹ From 1 to 2

² Using a UTP CAT 5 cable with RJ-45 connectors at both ends (the PINOUT is defined in Table 3 and Figure 4)

³ For example, the Kramer TP-124 or TP-46

⁴ RS-232 can be embedded only when the S/PDIF ANALOG Selector Button is set to the analog state

⁵ By default, both switches are set to NORM.

5 Installing on a Rack

This section provides instructions for rack mounting the unit.

Before Installing in a Rack

Before installing in a rack, be sure that the environment is within the recommended range:

Operating temperature range	+5° to +45° C (41° to 113° F)
Operating humidity range	10 to 90% RHL, non-condensing
Storage temperature range	-20° to +70° C (-4° to 158° F)
Storage humidity range	5 to 95% RHL, non-condensing



CAUTION!

When installing on a 19" rack, avoid hazards by taking care that:

1. It is located within the recommended environmental conditions, as the operating ambient temperature of a closed or multi unit rack assembly may exceed the room ambient temperature.
2. Once rack mounted, enough air will still flow around the machine.
3. The machine is placed straight in the correct horizontal position.
4. You do not overload the circuit(s). When connecting the machine to the supply circuit, overloading the circuits might have a detrimental effect on overcurrent protection and supply wiring. Refer to the appropriate nameplate ratings for information. For example, for fuse replacement, see the value printed on the product label.
5. The machine is earthed (grounded) in a reliable way and is connected only to an electricity socket with grounding. Pay particular attention to situations where electricity is supplied indirectly (when the power cord is not plugged directly into the socket in the wall), for example, when using an extension cable or a power strip, and that you use only the power cord that is supplied with the machine.

How to Rack Mount

To rack-mount a machine:

1. Attach both ear brackets to the machine. To do so, remove the screws from each side of the machine (3 on each side), and replace those screws through the ear brackets.

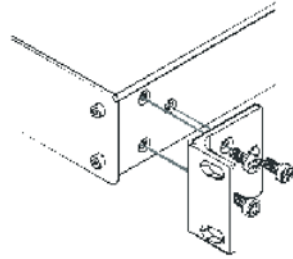

2. Place the ears of the machine against the rack rails, and insert the proper screws (not provided) through each of the four holes in the rack ears.

Note:

- In some models, the front panel may feature built-in rack ears
- Detachable rack ears can be removed for desktop use
- Always mount the machine in the rack before you attach any cables or connect the machine to the power
- If you are using a Kramer rack adapter kit (for a machine that is not 19"), see the Rack Adapters user manual for installation instructions available from: <http://www.kramerelectronics.com>

6 Connecting the TP-210A

This section describes how to connect the **TP-210A** (see section [6](#)), wire the CAT 5 LINE OUT RJ-45 Connectors (see section [6.1](#)), and wire the RS-232 connectors (see section [6.1](#)).

To connect the **TP-210A**, as illustrated in [Figure 3](#), do the following¹:

1. Connect a UXGA source (for example, a laptop's graphics card) to the UXGA INPUT 15-pin HD connector.
2. Connect an analog² audio source to the Audio IN 3.5mm mini jack, for example, using a Kramer C-GMA/GMA cable (VGA 15-pin HD +Audio jack to VGA 15-pin HD +Audio jack)³, and press the S/PDIF – ANALOG selector button.
3. Connect an RS-232 cable with a 9-pin D-sub connector at one end to the laptop, and a 2-pin terminal block connector at the other end to the RS-232 IN port (G, Rx).
4. Connect the UXGA OUT 1 15-pin HD connector to the UXGA acceptor (for example, a plasma display), and the ANALOG AUDIO² OUT 1 3.5mm mini jack connector to the analog audio connector on the acceptor. If required, connect the RS-232 G and TX1 terminal block connector to the RS-232 port on the acceptor.
5. Connect the UXGA OUT 2 15-pin HD connector to a UXGA acceptor (for example, a display), and the ANALOG AUDIO² OUT 2 3.5mm mini jack connector to the analog audio acceptor (for example, an AV Receiver).
6. Connect the LINE OUTPUT CAT 5 connectors as follows⁴:
 - The LINE OUT 1 RJ-45 connector on the TP-210A to the LINE IN RJ-45 connector on a TP-124⁵ unit via UTP cabling⁶ (with a range of up to 300ft (up to 100m))⁷
 - The LINE OUT 10 RJ-45 connector on the **TP-210A** to the LINE IN RJ-45 connector on another **TP-124**, via UTP cabling (with a range of up to 300ft (up to 100m))

1 Switch OFF the power on each device before connecting it to your TP-210A. After connecting your TP-210A, switch on its power and then switch on the power on each device

2 Alternatively, you can connect a digital audio source and acceptors and release the S/PDIF – ANALOG selector button

3 Not supplied. The full list of Kramer cables is on our Web site at <http://www.kramerelectronics.com>. You can also connect a UXGA source to the UXGA IN 15-pin HD connector, and a separate audio source to the AUDIO IN 3.5mm mini jack

4 You do not have to connect all the outputs

5 Refer to the separate user manual, which can be downloaded at <http://www.kramerelectronics.com>

6 For details of how to wire a CAT 5 LINE IN/LINE OUT RJ-45 connector, see section [6.1](#)

7 Alternatively, you can connect the Kramer TP-46, which can be connected to an additional TP-46 unit for transmitting the signal further

7. Connect the power cord¹.
8. If necessary, set the HS and VS switches² on the underside.

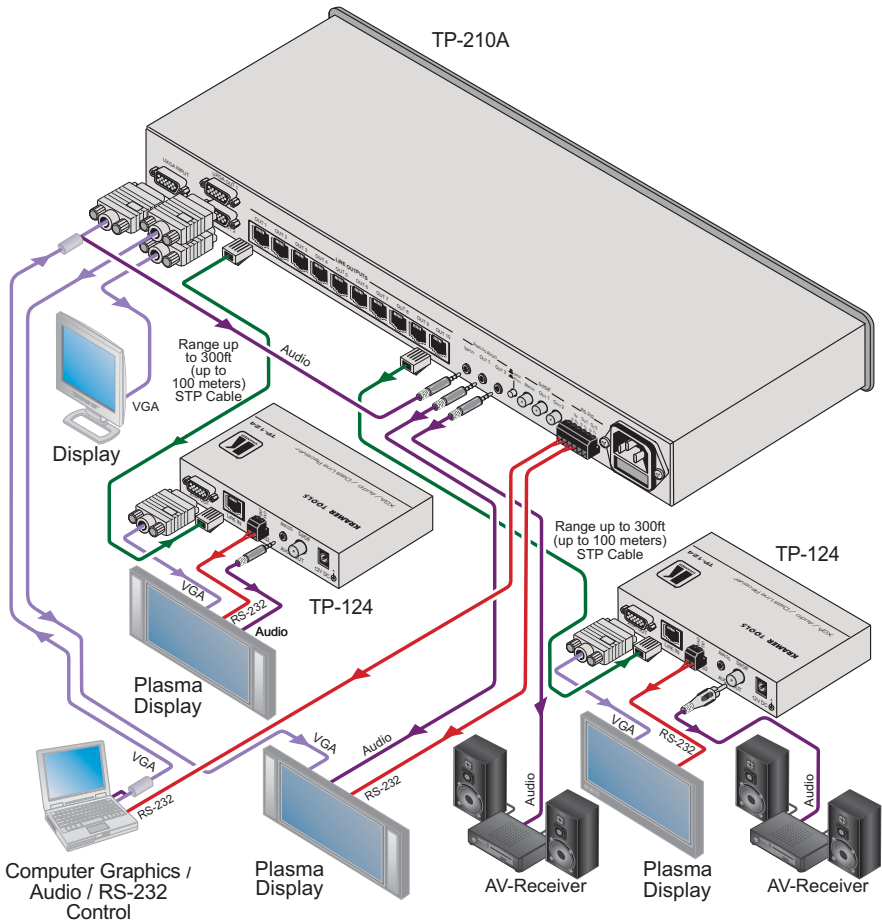

Figure 3: Connecting the TP-210A UXGA – Audio – RS-232 Line Transmitter/DA

¹ We recommend that you use only the power cord that is supplied with this machine

² By default, both switches are set down (for normal V SYNC and H SYNC polarity)

6.1 Wiring the CAT 5 LINE IN/LINE OUT RJ-45 Connectors

[Table 3](#) and [Figure 4](#) define the UTP CAT 5 PINOUT, using a straight pin to pin cable with RJ-45 connectors:

Table 3: CAT 5 PINOUT

EIA /TIA 568A		EIA /TIA 568B	
PIN	Wire Color	PIN	Wire Color
1	Green/White	1	Orange/White
2	Green	2	Orange
3	Orange/White	3	Green/White
4	Blue	4	Blue
5	Blue/White	5	Blue/White
6	Orange	6	Green
7	Brown/White	7	Brown/White
8	Brown	8	Brown
Pair 1	4 and 5	Pair 1	4 and 5
Pair 2	3 and 6	Pair 2	1 and 2
Pair 3	1 and 2	Pair 3	3 and 6
Pair 4	7 and 8	Pair 4	7 and 8

Figure 4: CAT 5 PINOUT

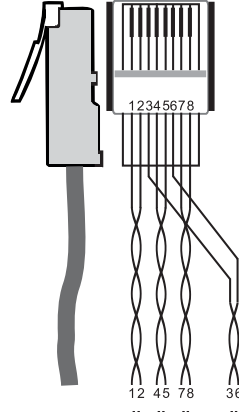

6.2 Wiring the RS-232 Connector

Prepare an RS-232 cable with a 9-pin D-sub connector at one end, and a 2-pin terminal block connector at the other end, as defined in [Figure 5](#):

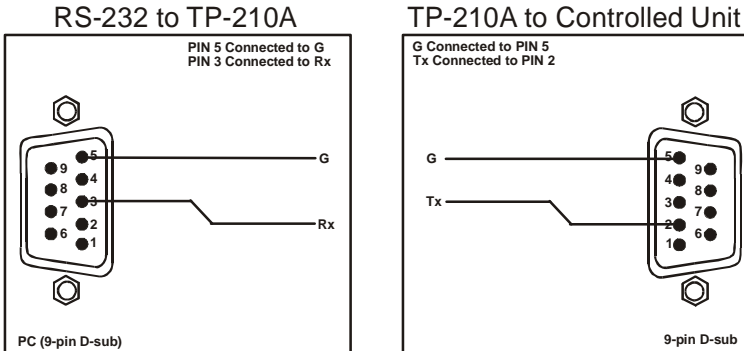

Figure 5: RS-232 PINOUT Connection

7 Technical Specifications

[Table 4](#) includes the technical specifications¹ of the **TP-210A**:

Table 4: Technical Specifications of the TP-210A

INPUTS:	1 UXGA video on a 15-pin HD connector, 1 unbalanced stereo audio on a 3.5mm mini jack, 1 S/PDIF on an RCA connector, 1 RS-232 with 1 Rx/D line on a terminal block connector.
OUTPUTS:	10 twisted pairs on RJ-45 connectors, 2 UXGA on 15-pin HD connectors, 2 unbalanced stereo audio on 3.5mm mini jacks, 2 S/PDIF on RCA connectors, 2 RS-232 with 2 Tx/D lines on terminal block connectors.
MAX. OUTPUT LEVEL:	Video: 1.6V; Audio: 2.3V.
POWER OUTPUTS:	12V DC 0.5A max via each RJ-45 output (PINs 4, 5)
RESOLUTION:	UXGA & 1080p
BANDWIDTH:	20Hz to 20kHz @ 1dB (audio)
SAMPLING RATE FOR S/PDIF:	48kHz
S/N RATIO:	AUDIO: >75dB
TOTAL GAIN:	AUDIO: Analog/analog: 0dB Analog/SPDIF: -12dBFS
TND+N:	AUDIO: <0.02%
POWER SOURCE:	100-240V AC, 50/60 Hz, 46VA
DIMENSIONS:	19" x 9.3" x 1U (W, D, H) rack mountable
WEIGHT:	3kg (6.6lbs) approx.
ACCESSORIES:	Power cord ² , rack "ears"

¹ Specifications are subject to change without notice

² We recommend that you use only the power cord that is supplied with this machine

LIMITED WARRANTY

Kramer Electronics (hereafter *Kramer*) warrants this product free from defects in material and workmanship under the following terms.

HOW LONG IS THE WARRANTY

Labor and parts are warranted for seven years from the date of the first customer purchase.

WHO IS PROTECTED?

Only the first purchase customer may enforce this warranty.

WHAT IS COVERED AND WHAT IS NOT COVERED

Except as below, this warranty covers all defects in material or workmanship in this product. The following are not covered by the warranty:

1. Any product which is not distributed by Kramer, or which is not purchased from an authorized Kramer dealer. If you are uncertain as to whether a dealer is authorized, please contact Kramer at one of the agents listed in the Web site www.kramerelectronics.com.
2. Any product, on which the serial number has been defaced, modified or removed, or on which the WARRANTY VOID IF TAMPERED sticker has been torn, reattached, removed or otherwise interfered with.
3. Damage, deterioration or malfunction resulting from:
 - i) Accident, misuse, abuse, neglect, fire, water, lightning or other acts of nature
 - ii) Product modification, or failure to follow instructions supplied with the product
 - iii) Repair or attempted repair by anyone not authorized by Kramer
 - iv) Any shipment of the product (claims must be presented to the carrier)
 - v) Removal or installation of the product
 - vi) Any other cause, which does not relate to a product defect
 - vii) Cartons, equipment enclosures, cables or accessories used in conjunction with the product

WHAT WE WILL PAY FOR AND WHAT WE WILL NOT PAY FOR

We will pay labor and material expenses for covered items. We will not pay for the following:

1. Removal or installations charges.
2. Costs of initial technical adjustments (set-up), including adjustment of user controls or programming. These costs are the responsibility of the Kramer dealer from whom the product was purchased.
3. Shipping charges.

HOW YOU CAN GET WARRANTY SERVICE

1. To obtain service on you product, you must take or ship it prepaid to any authorized Kramer service center.
2. Whenever warranty service is required, the original dated invoice (or a copy) must be presented as proof of warranty coverage, and should be included in any shipment of the product. Please also include in any mailing a contact name, company, address, and a description of the problem(s).
3. For the name of the nearest Kramer authorized service center, consult your authorized dealer.

LIMITATION OF IMPLIED WARRANTIES

All implied warranties, including warranties of merchantability and fitness for a particular purpose, are limited in duration to the length of this warranty.

EXCLUSION OF DAMAGES

The liability of Kramer for any effective products is limited to the repair or replacement of the product at our option. Kramer shall not be liable for:

1. Damage to other property caused by defects in this product, damages based upon inconvenience, loss of use of the product, loss of time, commercial loss; or
2. Any other damages, whether incidental, consequential or otherwise. Some countries may not allow limitations on how long an implied warranty lasts and/or do not allow the exclusion or limitation of incidental or consequential damages, so the above limitations and exclusions may not apply to you.

This warranty gives you specific legal rights, and you may also have other rights, which vary from place to place.

NOTE: All products returned to Kramer for service must have prior approval. This may be obtained from your dealer.

This equipment has been tested to determine compliance with the requirements of:

- EN-50081: "Electromagnetic compatibility (EMC);
generic emission standard.
Part 1: Residential, commercial and light industry"
- EN-50082: "Electromagnetic compatibility (EMC) generic immunity standard.
Part 1: Residential, commercial and light industry environment".
- CFR-47: FCC* Rules and Regulations:
Part 15: "Radio frequency devices
Subpart B Unintentional radiators"

CAUTION!

- Servicing the machines can only be done by an authorized Kramer technician. Any user who makes changes or modifications to the unit without the expressed approval of the manufacturer will void user authority to operate the equipment.
- Use the supplied DC power supply to feed power to the machine.
- Please use recommended interconnection cables to connect the machine to other components.
* FCC and CE approved using STP cable (for twisted pair products)



For the latest information on our products and a list of Kramer distributors, visit our Web site: www.kramerelectronics.com, where updates to this user manual may be found. We welcome your questions, comments and feedback.



Caution

Safety Warning:

Disconnect the unit from the power supply before opening/servicing.



P/N:



2900-000367

Rev:



3

Kramer Electronics, Ltd.

Web site: www.kramerelectronics.com

E-mail: info@kramerel.com

P/N: 2900-000367 REV 3